



NETWORK CCTV KIT

8CH NVR WITH 2TB & 5MP FULL COLOUR TURRETS

INTIPCK825TH2



Microphone



Human Detection



PoE



IP66



LED Light



Easy Mount



**FULL
COLOUR**
— with —
AI TECH

KEY FEATURES

CAMERA

- 1/3" progressive scan CMOS
- 2.8mm fixed lens
- Max resolution 2560×1920@20fps
- DWDR, 3D DNR, HLC, BLC, Defog
- Support intrusion and line crossing based on human detection
- Built-in IR LED and white lights, IR distance up to 20m, white light distance up to 20m
- 12V DC/PoE power supply
- IP66

NVR

- Up to 8ch IP cameras access
- Up to 5MP resolution recording
- 1 SATA hard disk up to 8TB
- Smart search & playback
- HDMI & VGA video output

KIT INCLUDES

- 8CH NVR x 1
- 2TB WD Purple HDD x 1
- 5MP AI Turret x 4
- HDMI Cable x 1

FIRE • SECURITY • INTERCOMS

17 Millicent Street, Burwood, VIC 3125 Australia
Tel: 1300 PSA PRODUCTS (1300 772 776)
Fax: (03) 9888 9993
enquiry@psaproducts.com.au

psaproducts.com.au





SPECIFICATIONS

Model	INTIPCT528DL2 (Turret Cameras)	
Camera	Image Sensor	1/3" Progressive Scan CMOS
	Electronic Shutter	Auto/Manual, 1/5 - 1/20,000s
	Min. illumination	Color: 0.1 Lux @ (F1.6,AGC ON), 0 Lux with illumination on
	S/N Ratio	55 dB
	Day & Night	IR cut filter
	Wide Dynamic Range	DWDR
	Illumination Distance	IR distance up to 20m (66.61 ft) White light distance up to 20m (66.61 ft)
	Illumination On/Off Control	Auto/Manual
	Pan/Tilt/Rotation Range	Pan: 0° - 360°, Tilt: 0° - 75°, Rotation: 0° - 360°
	Lens	Lens Type
Iris		Fixed Iris
Focal Length		2.8 mm
F Number		F1.6
Angle of View		H: 93.2°, V: 50.2°
Video	Max. Resolution	2560(H)×1920(V)
	Streaming Capability	2 Streams
	Stream/Frame Rate	Main Stream: 2560×1920, 2560×1440, 2304×1296, 1920×1080, 1280×720, 704×576 @ 20fps Sub Stream: 640×360 @ 20fps
	Bit Rate Control	CBR/VBR
	Bit Rate	Main Stream: 512kbps - 6144kbps Sub Stream: 128kbps - 1536kbps
Image	Image Adjustment	Brightness/Sharpness/Contrast/Saturation
	White Balance	Auto/Manual
	Mirror	Support
	Exposure Mode	Auto/Manual
	Day/Night Setting	Auto, Day, Night, Timing
	Noise Reduction	2D/3D DNR
	Image Enhancement	WDR, HLC, BLC, Defog
	Privacy Masking	Support
Audio	Audio Compression	G.711 (64kbps)
Alarm Event	Motion Detection	Support
	Smart Function	Support intrusion and line crossing based on human detection
Network	Protocols	IPv4, RTSP/RTP/RTCP, TCP/UDP,DHCP, DNS, DDNS, UPNP, ICMP, IGMP, NTP, SMTP, 802.1x, SNMP, HTTP/HTTPS, PPPOE
	Front End Access Protocol	ONVIF, SDK
	Max. User Access	4 Users
	Web Viewer	<IE11, Chrome, Firefox, Microsoft Edge
	Management Software	SunView
Interface	Network Interface	1 Ethernet (10/100 Base-T) RJ-45 Connector
	Microphone	Support
	Reset Button	Support
	SD Card Slot	Built-in, up to 256GB



Model		INTIPCT528DL2 (Turret Cameras)
General	Power Supply	DC12V (-15%~+25%)/POE (IEEE 802.3af)
	Power Consumption	Max 5 W
	Operating Temperature	-25°C ~ 55°C (-13°F ~ 131°F)
	Operating Humidity	Less than 90% RH
	Ingress Protection	IP66
	Certifications	CE/FCC
	Casing	Metal + Plastic
	Dimensions	Φ111 × 95mm
	Net Weight	0.35 kg (0.77 lb)

DIMENSIONS

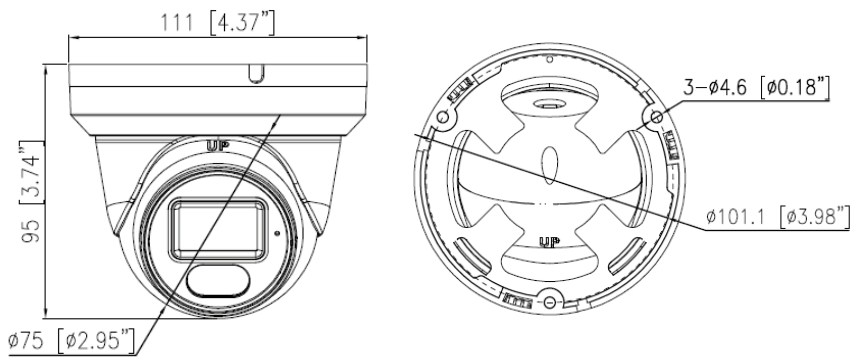

ACCESSORY



Pendant Cap
SN-CBK202A



Wall Bracket
SN-CBK501



SPECIFICATIONS

Model	INTNVR108E (NVR)	
Video Input	IP Camera Input	8 Channel
	Incoming Bandwidth	60 Mbps
	Outgoing Bandwidth	60 Mbps
Video Output	HDMI Output	1920×1080, 1440×900, 1280×1024
	VGA Output	1920×1080, 1440×900, 1280×1024
	Decoding Capacity	1ch 5MP, 4ch 1080P, 8ch D1@30fps
	Dual Stream	Support
	Multi-screen Display	1/4/8/9
Recording	Resolution	5MP, 4MP, 3MP, 1080P, 720P, D1 etc.
	Recording Mode	Manual, Schedule (Regular, Continuous), Event
	Trigger Events	Motion Detection, Video Loss, Alarm in, IVS
Playback and Backup	Sync Playback	9/4/1
	Search Mode	Time /Date, Alarm, Picture grid, Event
	Backup Mode	USB Device, Network
Network	Interface	1 RJ-45 port (10/100 Mbps)
	PoE	8 Ports (IEEE 802.3af), 48W
	Network Function	HTTP, HTTPS, TCP/IP, IPv4, UPnP, UDP, RTSP, SMTP, NTP, DNS, DHCP, P2P, IP Filter, DDNS, 802.1X, SNMP, 3G/4G, PPPoE
	Remote Users	8 users
	Smart Phone	iPhone, iPad, Android
	Interoperability	ONVIF, SDK, CGI
	Storage	HDD
	Cloud Storage	Support
Interface	Audio I/O	1ch Audio output
	Alarm Input	N/A
	Alarm Output	N/A
	USB	2 ports (USB 2.0 × 2)
General	Power Supply	DC48V/1.35A
	Power Consumption	< 5 W (without HDD)
	Operating Conditions	-10 °C - 50 °C (14 °F - 122 °F)
	Storage Conditions	Less than 90% RH
	Certifications	CE/FCC
	Dimensions	255 × 237 × 47.5 mm (10.04 × 9.33 × 1.87 inch)
	Net Weight	1 kg (2.2 lb) without HDD



DIMENSIONS

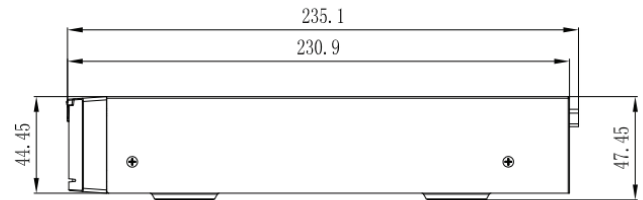
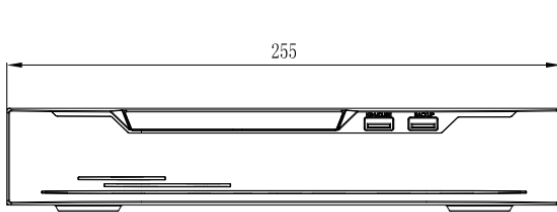

REAR PANEL



FIRE • SECURITY • INTERCOMS